

BTC Series

Up to 6 LPM Free Flow



Miniature Diaphragm Pumps (air/gas)

BTC Miniature Diaphragm Pumps are a series of brush and brushless DC motor driven pumps, which are tailored to meet specific application performance requirements. An innovative compact design incorporates leading edge technologies that allow them to operate more efficiently than existing pump designs. BTC Pumps offer multiple component configurations allowing them to be used for either vacuum, pressure, or alternating vacuum and pressure operations. BTC series is ideal for a wide range of pressures and low noise applications.

Typical Applications

- Gas Analysis
- Anesthesia Monitors
- CO₂ Monitors
- Patient Monitoring
- Wound Therapy
- Urinalysis
- Medical/Training Mannequin

Features

- Innovative and efficient engineering designs enable the BTC Series to push the performance envelope in a lightweight, compact size.
- Using our proprietary advanced diaphragm elastomer and superior brushless motor design sets the highest benchmark for service-free operation that exceeds 10,000 hours.
- Incorporating the lightweight EZ Mount Accessory facilitates simple system assembly while dampening vibration and reducing noise levels.
- RoHS compliant. 

Product Specifications*

Physical Properties

Operating Environment¹ :
41 to 122°F (5 to 50°C)
Storage Environment :
-4 to 212°F (-20 to 100°C)
Media:
Air, Argon, Helium, Nitrogen, Oxygen, and other non-reacting gases
Humidity:
0% - 80% Relative Humidity
Noise Level² :
As low as 45 dB @ 12 in (30 cm)
<i>Muffler recommended for additional noise reduction (see accessories)</i>
Pump Assembly Rated Life³ :
PMDC Iron Core Brush - 3,000 hrs
Brushless Slotted - 10,000 hrs
Brushless Slotless - 10,000 hrs
Weight:
6.5 oz. (184 g) PMDC Iron Core Brush
4.5 oz. (128 g) Brushless Slotted
7.4 oz. (210 g) Brushless Slotless

Electrical

Motor Type (DC):
PMDC Iron Core Brush, Brushless Slotted, Brushless Slotless
Nominal Motor Voltages⁴:
6, 12, or 24 VDC
<i>Other voltages available upon request</i>
Electrical Termination:
PMDC Iron Core Brush: 22 AWG Wire Leads, Length 10" (254 mm)
Brushless Slotted Motor: 22 AWG Wire Leads, Length 20" (508 mm)
Brushless Slotless: 22 AWG Wire Leads Length 20" (508 mm)
Current Range⁵:
50 - 900 mA

Wetted Materials

Diaphragm:
EPDM, AEPDM, FKM
Valves:
EPDM, FKM
Pump Head:
Vectra (Liquid Crystal Polymer)

Pneumatic

Head Configuration:
Single
Maximum Unrestricted Flow:
Flow: 6 LPM
Pressure Range:
0 - 30 psig (0-1.93 bar) Flat
0 - 20 psig (0-1.38 bar) Convoluted
Vacuum Range:
0 - 23 in Hg (0-584 mm Hg) Flat
0 - 20 in Hg (0-508 mm Hg) Convoluted
Filtration:
40 microns - recommended
Efficiency at Free Flow⁶:
PMDC Iron Core Brush: 1.2 LPM/Watt (PN: C103E-13)
Brushless Slotted: 1.4 LPM/Watt (PN: C134D-13)
Brushless Slotless: 1.5 LPM/Watt (PN: C190-12)

* See Appendix A for details.

Performance Specifications

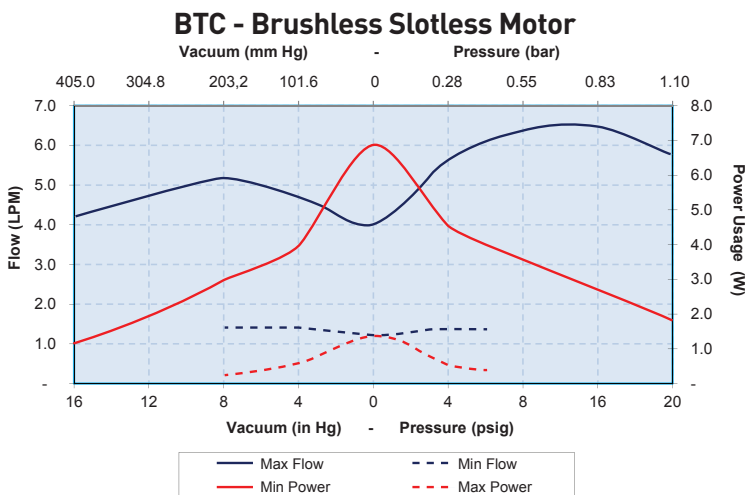
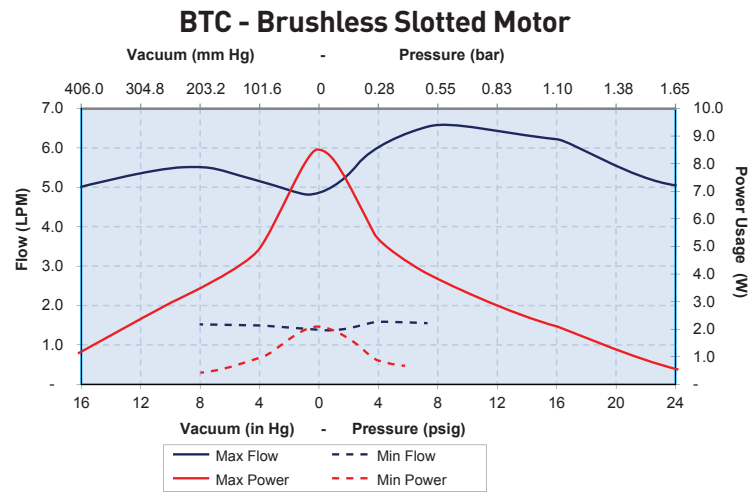
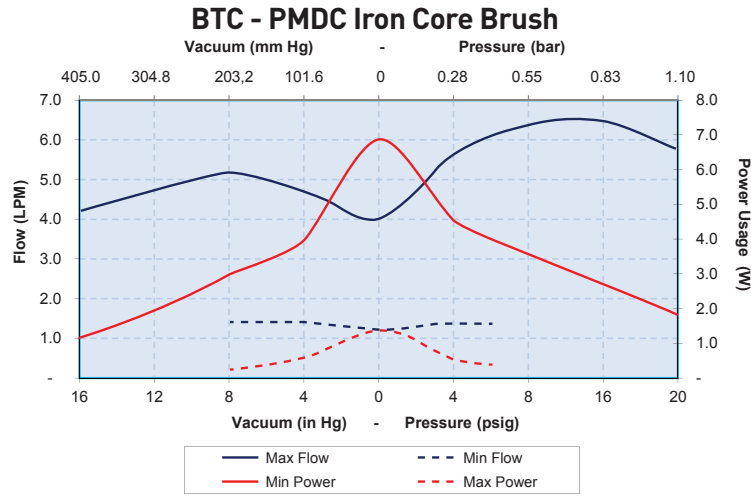

The above graphs represent an example of performance for the pump series handling air at 800 feet (244 m) above sea level at 75 degree F (24 C). Performance will vary depending on barometric pressure and media temperature. A variety of configurations can be accommodated to meet application requirements. Curves are representative of standard pump configurations. Pump configurations could be customized for higher or lower flows depending on specific customer requirements.

Please contact Parker Precision Fluidics Applications Engineering for other considerations.



BTC Series

Miniature Diaphragm Pumps (air/gas)

Sizing and Selection

BTC Series	PMDC Iron Core Brush	Brushless Slotted Motor	Brushless Slotless Motor
------------	----------------------	-------------------------	--------------------------

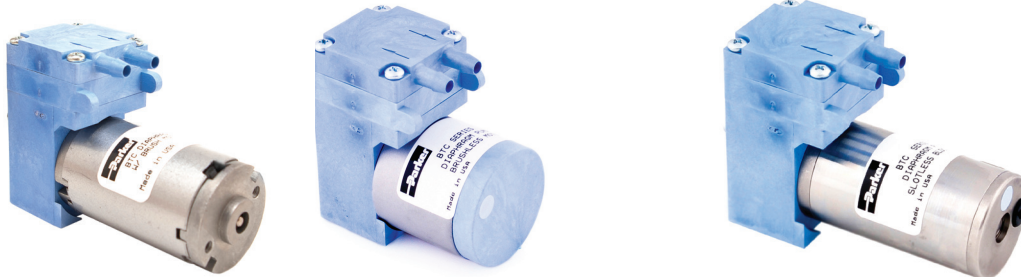

	PMDC Iron Core Brush	Brushless Slotted Motor	Brushless Slotless Motor
Efficiency¹	Good	Better - Up to 60% motor efficiency at low loads	Best - Up to 75% motor efficiency at high power levels
Life²	Good - 3,000 hrs	Best - 10,000 hrs	Best - 10,000 hrs
Cost	Best	Better	Premium
Noise	Good	Better	Best

Mounting Guidelines:

- Bracket options available for mounting consideration (See *EZ Mount catalog pages*).
- Hole in the center of the bottom of housing is for manufacturing only—not to be used for mounting.
- Mounting holes are drilled for #6-20 self-tapping screws with 1/4" (6 mm) thread engagement torque to 4 in-lbs (0.45 N-m).

Port Connections:

- Barbs are sized for 1/8" (3 mm) ID tubing, 70-80 durometer recommended.
- Flow direction is marked on the pump head with arrows.

Mechanical Integration

Dimensions

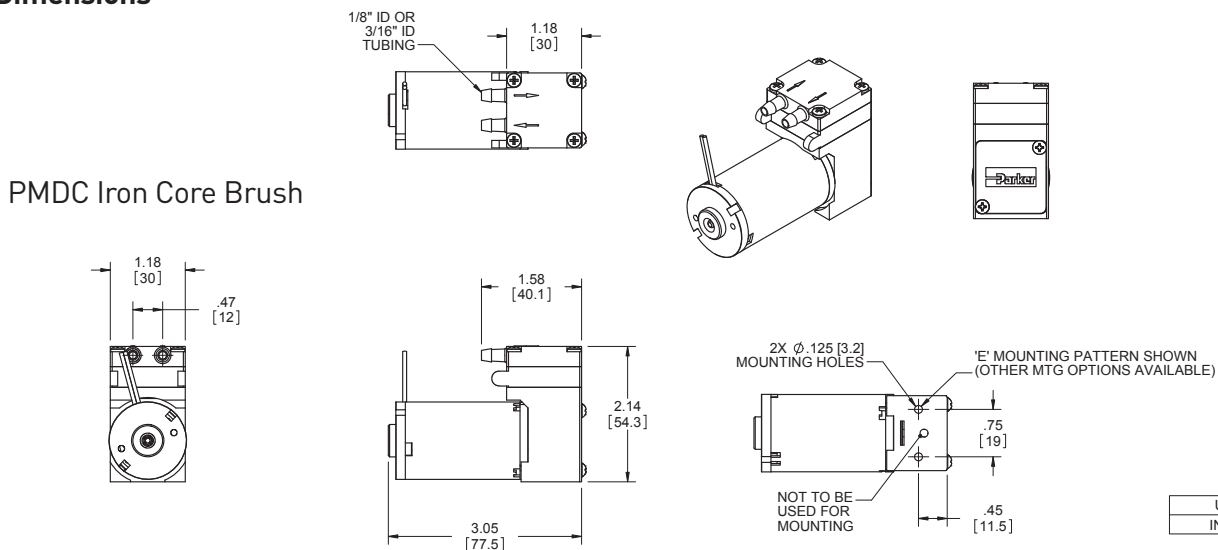

Mechanical Integration

Dimensions

Brushless Slotted Motor

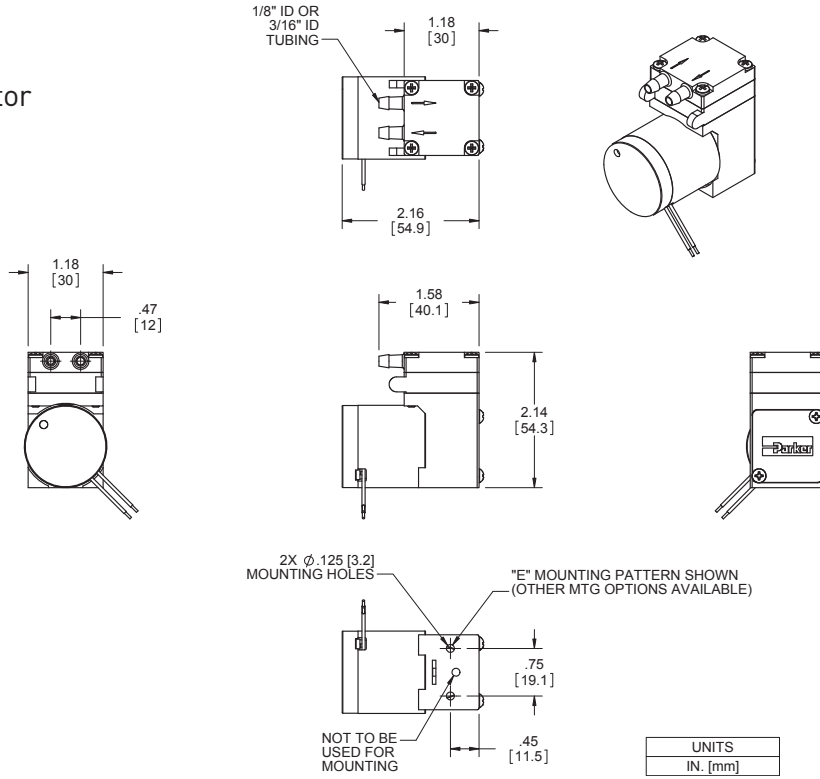

Brushless Slotless Motor

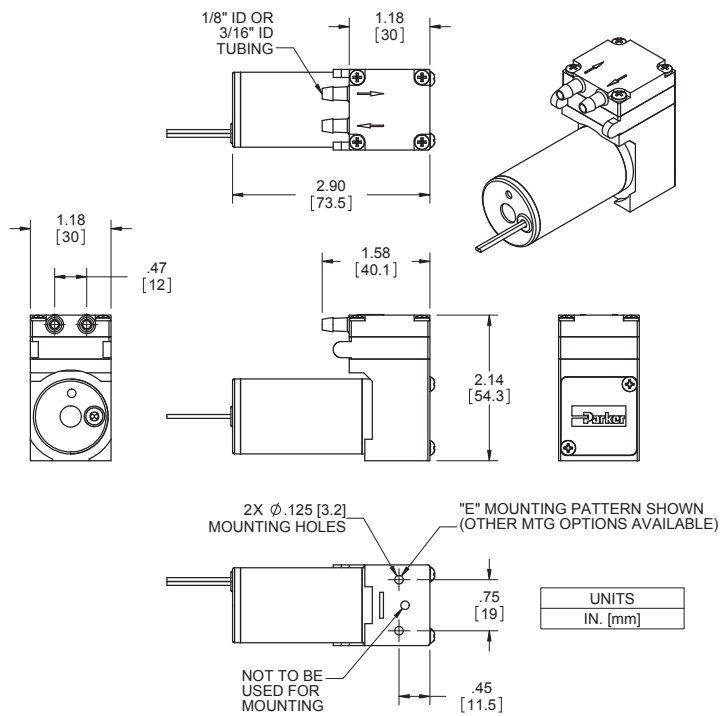

BTC Series

Miniature Diaphragm Pumps (air/gas)

Electrical Integration and Motor Control

PMDC Iron Core Brush Motor

2 Wire	Red (+), Black (-)
Wire specification	22AWG, Insulation OD 0.051 in (1.30 mm), 10" (254 mm) Wire Leads

Brushless Motor Control Options

2 Wire	Red (+), Black (-)
3 Wire (Speed Control)	Red (+), Black (-), White (PWM) or Yellow (Analog)
4 Wire (Speed Control & Feedback)	Red(+), Black (-), White (PWM) or Yellow (Analog), Blue (Tachometer)
Wire specification	22AWG, Insulation OD 0.051 in (1.30 mm), 20" (508 mm) Wire Leads

Other Motor Control Considerations

The drive electronics for the BLDC motors are integrated into the motor itself, all that is needed is a power supply with the sufficient voltage and current.

Key Things to Remember

The pump is not a pressure holding device. An external check valve is recommended, if there is a pressure holding requirement.

Pump orientation does not affect performance or life.

Pulse Width Modulation (PWM)

Pulse-width modulation is a commonly used technique for controlling DC motors.

The average value of the voltage fed to the motor is controlled by turning a switch between the voltage supply and the motor on-and-off at a fast pace. The longer the switch is on compared to the off time, the higher the power supplied to the motor.

The PWM switching frequency varies for different types of devices, and is selected based on how it affects the device. For example, some applications require a faster switching frequency to prevent audible noise or electrical noise.

The term duty cycle describes the ratio of on-time to the period (one complete on-and-off cycle). Duty cycle is normally expressed as a percentage of on-time, 100% being full-power and 50% being half-power.

The advantage of PWM is the reduction of power-loss due to switching versus other control methods. Parker Hannifin recommends controlling the pump using 15kHz - 20 kHz frequency range.

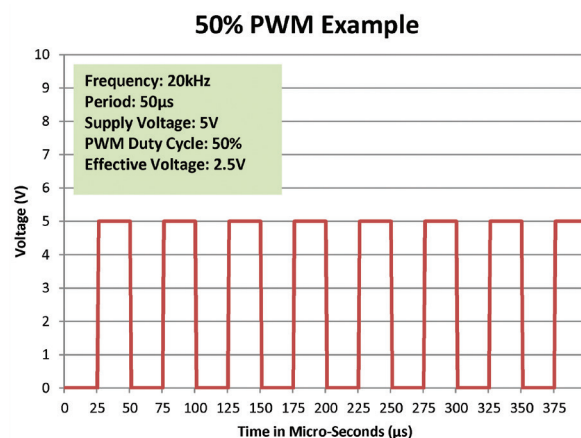
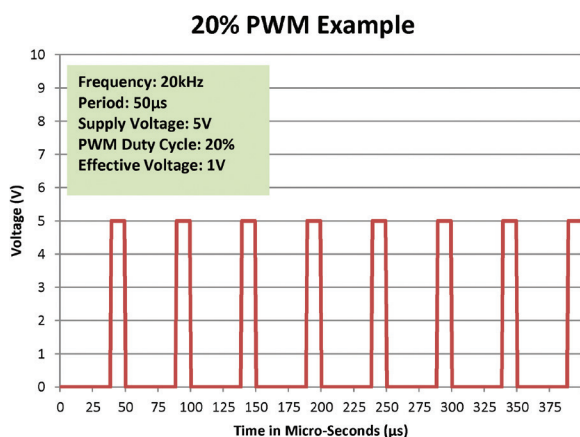

Typical Flow Diagram

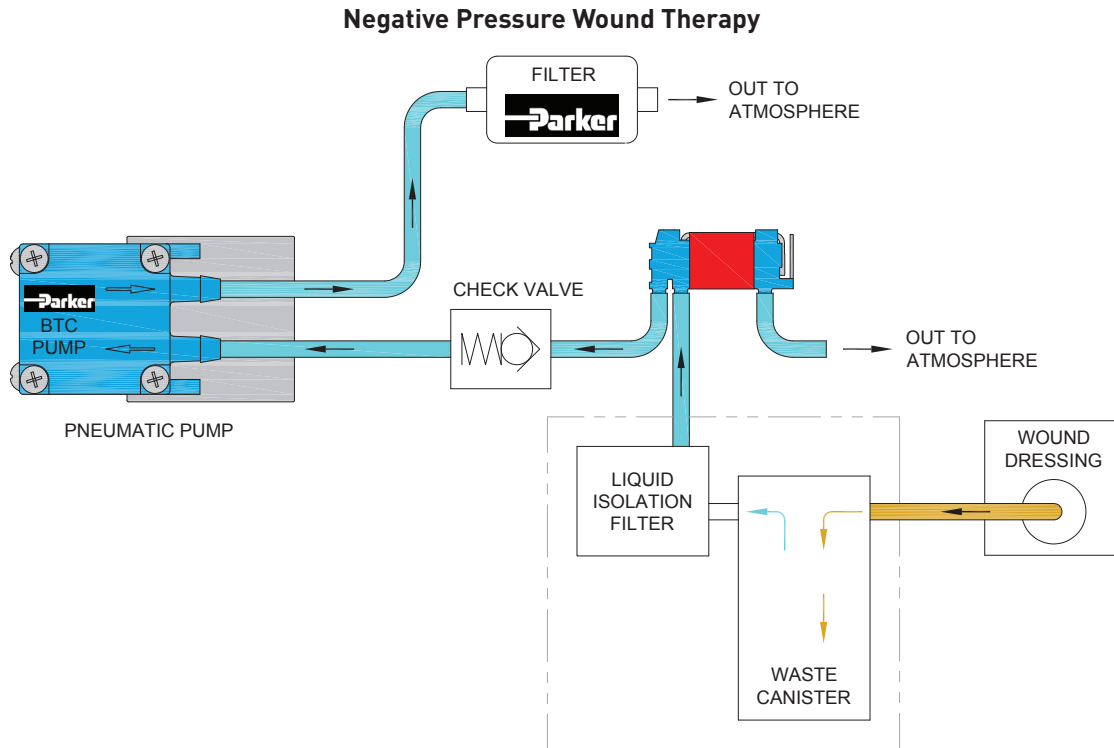

Ordering Information

Filter-Mufflers also available to assist with filtration and optimize noise reduction.

Part Number: 00492-15
(Filters to 10 microns)

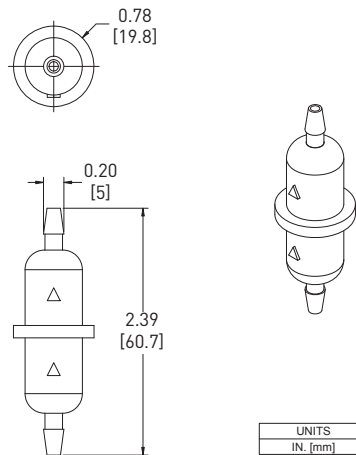

BTC Series

Miniature Diaphragm Pumps (air/gas)

Accessory Information

EZ Mount available

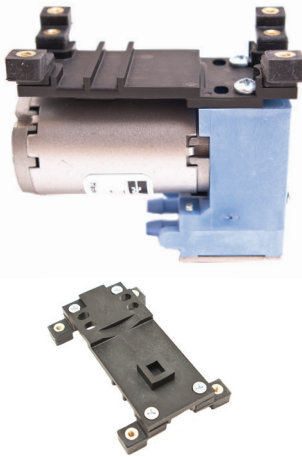

EZ Mount provides ease of installation and effective control of vibration transfer. EZ Mount was designed to mount easily to the Precision Fluidic BTC Family of diaphragm pumps.

Features

- Isolation feet on the EZ mount can be rotated in any one of three ninety-degree planes and is designed for top-down or bottom-up mounting providing simple installation.
- EZ Mount was designed to minimize weight added to the pump assembly. Approximate weights are: Style A - 0.63 oz (18 g), Style B - 0.71 oz (20 g).
- Effectively absorbs vibration to minimize most vibration-induced noise and vibration transfer into an instrument.
- Designed to keep height and size to a minimum.
- Engineered for Parker BTC pumps to ease integration into your system.

Physical Properties

Operating Environment:

41 - 158°F (5 - 70°C)

Humidity:

0 - 95% Relative Humidity

Base Plate:

Noryl GTX830

Feet:

Silicone

Feet Insert:

Brass

Hardware:

Zinc-Plated Steel

EZ Mount kits include all necessary hardware and detailed instructions.

Isolation Feet are available in either threaded or thru-hole clearance for standard #4-40 (M3.5 for clearance hole only) or #6-32 hardware and can be mounted in any of three ninety-degree planes.

Dimensions

Style A

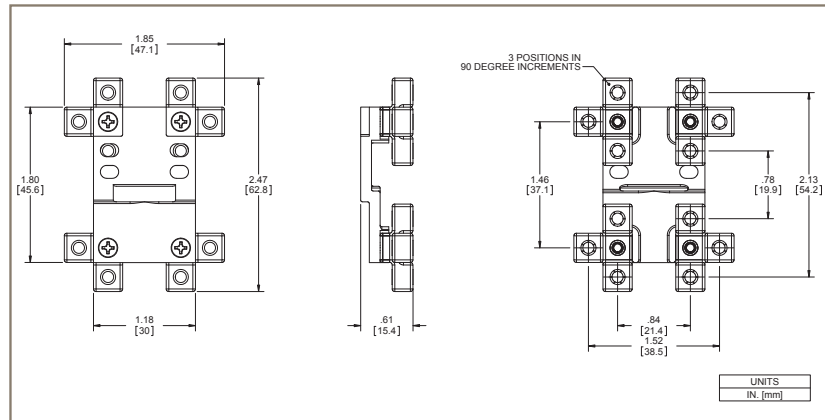

Style B

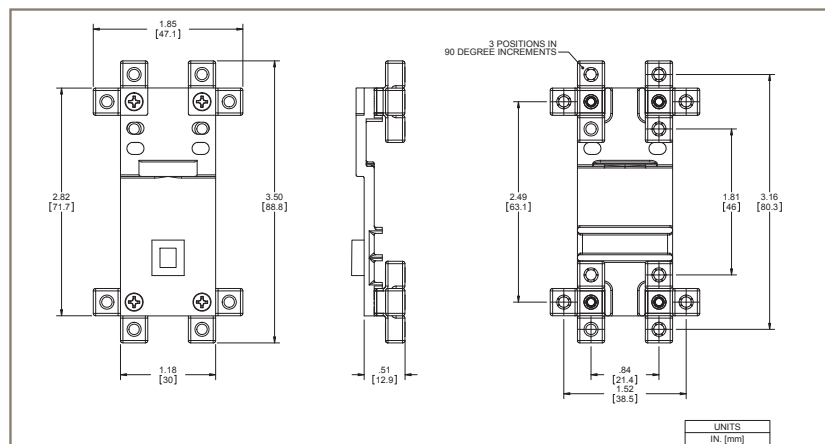

Miniature Diaphragm Pumps (air/gas)

BTC Series

Ordering Information

BTC Single Head Pumps - General Purpose

Part No.	Vacuum: LPM @ Load					Free Flow	Pressure: LPM @ Load						Max		Motor Type	PCD*		Wetted Materials	
	20 in Hg	16 in Hg	12 in Hg	8 in Hg	4 in Hg		4 psig	8 psig	12 psig	16 psig	20 psig	24 psig	28 psig	Vac in Hg		Press psig	VDC		mA
	508 mm Hg	406 mm Hg	305 mm Hg	203 mm Hg	102 mm Hg	0	276 mbar	55 mbar	827 mbar	1103 mbar	1379 mbar	1655 mbar	1931 mbar						
H022C-11		0.3	0.9	1.4	1.8	3.2	2.0	1.4	1.1	0.9	0.5	0.2		18.0	24.0	Brushless Slotted	12	380	AEPDM,EPDM,EPDM
H041B-11		0.3	0.9	1.4	1.8	3.2	2.0	1.4	1.1	0.9	0.5	0.2		18.0	24.0	Brush PMDC	6	665	AEPDM,EPDM,EPDM
H054B-11		0.3	0.9	1.4	1.8	3.2	2.0	1.4	1.1	0.9	0.5	0.2		18.0	24.0	Brushless Slotted	24	220	AEPDM,EPDM,EPDM
H084-11		0.3	0.9	1.4	1.8	3.2	2.0	1.4	1.1	0.9	0.5	0.2		18.0	24.0	Brush- PMDC	24	180	AEPDM,EPDM,EPDM
H085-11		0.3	0.9	1.4	1.8	3.2	2.0	1.4	1.1	0.9	0.5	0.2		18.0	24.0	Brush- PMDC	12	370	AEPDM,EPDM,EPDM
H127-11		0.3	0.7	1.4	2.1	2.7	2.2	1.8	1.4	1.0	0.6	0.3		18.0	24.0	Brushless Slotless	24	205	AEPDM,EPDM,EPDM
H124-11		0.3	0.9	1.4	2.1	2.6	2.1	1.7	1.3	1.0	0.6	0.3		18.0	24.0	Brushless Slotless	12	380	AEPDM,EPDM,EPDM
H004C-11			0.6	1.0	1.7	2.5	1.7	1.2	0.8	0.3				16.0	20.0	Brushless Slotted	12	350	AEPDM,EPDM,EPDM
H037A-11			0.7	1.2	1.8	2.5	1.7	1.2	0.8					16.0	17.0	Brush- PMDC	12	265	AEPDM,EPDM,EPDM
H050D-11			0.6	1.1	1.7	2.5	1.7	1.2	0.9	0.5				16.0	20.0	Brushless Slotted	24	175	AEPDM,AEPDM,EPDM
H061-11			0.5	0.9	1.6	2.5	1.6	1.1	0.8	0.4				16.0	20.0	Brush- PMDC	6	620	AEPDM,EPDM,EPDM
H070A-11			0.6	1.1	1.8	2.5	1.7	1.2	0.8					16.0	17.0	Brush- PMDC	24	125	AEPDM,AEPDM,EPDM
L008C-11			0.3	0.7	1.5	1.5	0.6	0.3**						10.0	7.0	Brushless Slotted	12	195	AEPDM,AEPDM,EPDM
L037B-11			0.4	0.9	1.5	1.5	0.9	0.3						12.0	10.0	Brush- PMDC	24	95	AEPDM,AEPDM,EPDM
L045B-11			0.4	0.7	1.5	1.5	0.7	0.3						12.0	10.0	Brushless Slotted	24	110	AEPDM,AEPDM,EPDM
L052C-11			0.4	1.0	1.5	1.5	0.9	0.3						12.0	10.0	Brush- PMDC	12	160	AEPDM,AEPDM,EPDM
L074-11			0.2	0.5	1.2	1.2	0.5	0.3*						9.0	7.0	Brush- PMDC	6	270	AEPDM,AEPDM,EPDM

* PCD: Peak Current Draw ** @ 6psi (414 mbar)

BTC Single Head Pumps - High Flow

Part No.	Vacuum: LPM @ Load					Free Flow	Pressure: LPM @ Load						Max		Motor Type	PCD*		Wetted Materials	
	20 in Hg	16 in Hg	12 in Hg	8 in Hg	4 in Hg		4 psig	8 psig	12 psig	16 psig	20 psig	24 psig	28 psig	Vac in Hg		Press psig	VDC		mA
	508 mm Hg	406 mm Hg	305 mm Hg	203 mm Hg	102 mm Hg	0	276 mbar	55 mbar	827 mbar	1103 mbar	1379 mbar	1655 mbar	1931 mbar						
C134D-12		0.9	1.7	2.5	3.4	6.0								20.0		Brushless Slotted	12	485	AEPDM,EPDM,EPDM
C117H-12		0.9	1.7	2.5	3.5	6.0								20.0		Brushless Slotted	24	400	AEPDM,EPDM,EPDM
C190-12		0.7	1.5	2.5	3.5	4.7								19.0		Brushless Slotless	12	400	AEPDM,EPDM,EPDM
C191-12		1.0	1.8	2.7	3.7	4.4								21.0		Brushless Slotless	24	250	AEPDM,EPDM,EPDM
C103E-12		0.9	1.8	3.0	3.9	6.0								20.0		Brush-PMDC	12	510	AEPDM,AEPDM,EPDM
C153A-12		1.0	1.7	2.6	3.5	6.0								20.0		Brush-PMDC	24	245	AEPDM,AEPDM,EPDM
C134D-13						6.0	3.8	3.0	2.4	1.9	1.4	1.0		24.0		Brushless Slotted	12	700	AEPDM,EPDM,EPDM
C117H-13						6.0	3.7	2.7	2.0	1.5	0.9	0.4		24.0		Brushless Slotted	24	390	AEPDM,EPDM,EPDM
C190-13						4.3	3.4	2.7	2.0	1.6	1.2			22.5		Brushless Slotless	12	530	AEPDM,EPDM,EPDM
C191-13						4.0	3.2	2.6	1.9	1.4	1.0			21.0		Brushless Slotless	24	260	AEPDM,EPDM,EPDM
C103E-13						6.0	3.9	3.0	2.2	1.4	0.6			24.0		Brush-PMDC	12	670	AEPDM,AEPDM,EPDM
C153A-13						6.0	4.0	3.1	2.4	1.6	1.1			24.0		Brush-PMDC	24	310	AEPDM,AEPDM,EPDM

Note: The Ordering Information Section includes a few selected part numbers for the product line. Other performances and configurations are available. Please contact your Sales Representative or an Application Engineer to discuss your application needs.

*PCD: Peak Current Draw



BTC Series**Miniature Diaphragm Pumps (air/gas)****Ordering Information****Accessory Information**

Part No.	Filtering Level (Micron)	Filter Area	Internal Volume	Operating Limitations:			Wetted Materials
				Max Temperature	Min Temperature	Max Pressure	
00492-15	10	1.71 in ² (11 cm ²)	0.24 in ³ (3.9 cm ³)	80°C	32°C	65 PSI (4.48 bar)	Polypropylene
Filter-Mufflers: To assist with filtration and optimize noise reduction. Tubing: Recommendation 1/8" (3mm) ID.							

EZ Mount for BTC Single Head Pump with PMDC Iron Core Brush Motor

Part Number	Style	Description
00329-10-A45S	B	#4-40 Threaded
00329-10-B45S	B	#4 / M3.5 Clearance
00329-10-D45S	B	#6-32 Threaded
00329-10-C45S	B	#6 Clearance

EZ Mount for BTC Single Head Pump with Brushless Slotted Motor

Part Number	Style	Description
00328-10-A45S	A	#4-40 Threaded
00328-10-B45S	A	#4 / M3.5 Clearance
00328-10-D45S	A	#6-32 Threaded
00328-10-C45S	A	#6 Clearance

EZ Mount for BTC Single Head Pump with Brushless Slotless Motor

Part Number	Style	Description
01074-10-A45S	B	#4-40 Threaded
01074-10-B45S	B	#4 / M3.5 Clearance
01074-10-D45S	B	#6-32 Threaded
01074-10-C45S	B	#6 Clearance

Please click on the Order On-line button below (or go to www.parker.com/precisionfluidics/btc) to configure the BTC-II Miniature Diaphragm Pump for your application.

Serviceable – PPF products are designed for use through the rated life and Parker does not sell replacement parts, nor is it recommended to service these in the field

Note: In addition to Parker's innovative and flexible pump designs, we offer applications engineering expertise to our customers in order to configure and recommend the optimal pump for the application. Contact Parker Applications Engineering to discuss and configure alternate pump configurations to meet your specific application requirements. Providing information on the following requirements will assist us in developing an optimal solution for your application:

- Noise
- Operating Pressure / Vacuum
- Power Consumption
- Life Requirement
- Function in the Application
- Size
- Motor Control
- Media
- Voltage



Appendix A

All performance data is typical based on standard conditions: 70°F and 14.7 psia (21°C and 1 bar).

1. Duty Dependent. For operation above 122°F (50°C) consult factory
2. Noise is dependent on the configuration and operation of the pump in the application. Parker has the ability to tailor the pump configuration when noise is a critical criterion in the effort to meet the performance requirements of the application. Noise level is tested to Parker protocol P-105.
3. Life rating can vary depending on application and operating conditions.
4. Custom motor options available. Custom motors may require a significant application potential. The standard motors can be configured with a special winding to meet a particular operation point at a specified voltage
5. Current range is dependent on motor type, voltage, pressure/vacuum and flow requirement. Lower levels possible depending on application.
6. Pump efficiency is a measure of the flow rate generated per unit of power consumed. Efficiency may change dependent on application and operating condition at free flow.

